

# Understanding and building the OCF dipole

By Ron Bertrand VK2DQ - © 2007

## Want to build a simple, efficient, multiband antenna?

One of the best and inexpensive multiband antennas is the off-centre-fed (OCF) dipole. These are wonderfully simple antennas that permit multiband operation with little or no tuning. The OCF dipole does require a **balun**.

In fact the only difficult part of an OCF dipole is the balun and I will be explaining how the balun works and also how you can make your own.

We shall see how many choose to either use a 4:1 or 6:1 balun for an OCF dipole. I use an OCF dipole with a 4:1 balun and find it works very well and the 4:1 balun is a bit smaller, lighter and cheaper to construct than a 6:1. However for those who want to construct a 6:1 balun I will explain how that can be done as well.

Before we get going let's try and understand what the OCF dipole is all about. It all started with the Windom antenna...

### Windom Antenna

The Windom was once a very popular multiband antenna. The antenna is named after its inventor, Loren G. Windom, W8GZ who first published details of his antenna design in 1929. The Windom is just a horizontal halfwave of wire on the lowest frequency of operation. The Windom uses a single wire as the alleged feedline. Instead of being fed in the centre the single wire 'feeder' is attached to the dipole 14% off centre. See *Figure 1*.

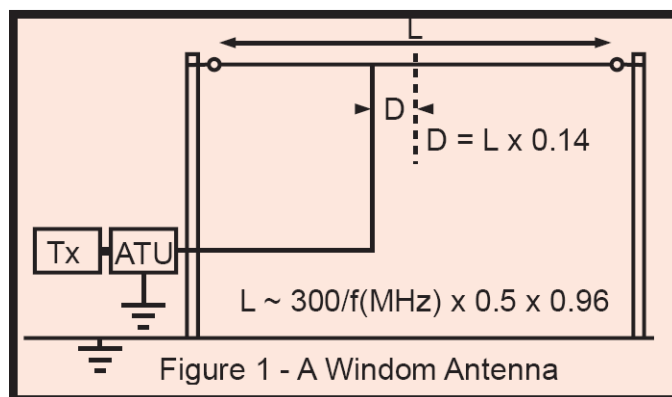

There is no transmission line used on the original Windom. A single wire is attached 14% off the centre of the dipole. This wire feeder is then connected to an antenna tuning unit (ATU). The idea of feeding the half wave off centre was to find a point where the

impedance "is easier for the tuner to cope with" across multiple bands which are related to even harmonic lengths of the dipole.

The Windom was an 80-metre antenna. The single wire was thought to have an impedance of 600 Ohms against ground.

The logic goes like this: since the centre of a dipole is about 70 Ohms and the ends 2-3000 Ohms, the theory goes that we should be able to find any impedance between these two extremes along the antenna.

The theory is good but we need to translate it into practice. So a point could be found, *presumed to be 14% off centre*, where the feedpoint impedance was 600 Ohms. While the theory might sound good I have some difficulty with this hypothesis. First the feedpoint is not at the antenna. The feedpoint is at the station end of the vertical wire. The so-called *feeder* of the Windom is a *radiator* as much as the halfwave top section is.

The *feeder* on the original Windom was supposed to come away from the dipole at right angles for at least one half the length of the antenna; in other words, a quarterwave. I am a bit lost regarding the reason for this distance, but I can easily see the Windom as a vertical wire antenna with a large capacitive hat.

Still the antenna enjoyed a lot of popularity for many years because it did work with an ATU. It could be tuned on multiple bands. However, so could almost any bit of wire if high voltage points were avoided. A high voltage point occurs when the wire length is a half or multiple thereof; in other words, a high impedance point.

Since the *feeder* wire radiates there will be RF radiation in the shack. With today's concerns about the potential dangers of

electromagnetic radiation, this should be avoided. The old-style Windom would not meet our present-day EMR safety requirements if you are using 100 Watts or more. Indeed my first introduction to the Windom was at a Jamboree of the Air around 1976. That was the year I received my first RF burn as a direct consequence of

placing my forearm close to the "feeder" wire of the Windom while the station was transmitting. While it hurt I did think it was *cool* at the time. I felt like I had been initiated to the RF burn club. Such a risk is not acceptable today. RF energy can cause cumulative and permanent damage to tissues of the body.

It is often said about antennas like the Windom that they are "worked against their image in the ground". I think statements like that are most confusing. It conjures up a picture of something actually being in the ground.

A Windom is just a horizontal halfwave without a real transmission line. It's not really a halfwave antenna because its so-called *feeder* radiates and is, therefore, part of the antenna.

Like most antennas, reflection of radiation from the ground modifies the radiation pattern. That is what is meant by: it works against its image.

So why talk about the Windom if we are not going to rate it well?

The principle of finding a point on an antenna where an acceptable or workable impedance match can be obtained across multiple bands is sound.

This was the objective with the Windom. Find a point on a dipole that will permit the best multiple-band operation. Did the Windom achieve this?

Well, I suppose it did but *without* an antenna tuner and the more robust transmitter output tuning found in older transmitters you would have trouble with a Windom today.

An improvement on the Windom is the Off-Centre-Fed Dipole or just OCF.

### Off-Centre-Fed Dipole

OCF's are a descendant of the Windom. A standard horizontal dipole is fed at a position other than the centre.

The objective being to find an impedance on the antenna that can provide a reasonably good match to the transmitter across multiple bands which are even harmonically related, such as 80, 40, 20, 10 and 6 metres.

The idea of feeding an antenna off-centre is not new but for some, at least at first, it









